

01-03-00

A

Please type a plus sign (+) inside this box →

PTO/SB/05 (2/98)
Approved for use through 09/30/00. OMB 0651-0032
Patent and Trademark Office: U.S. DEPARTMENT OF COMMERCE

Under the Paperwork Reduction Act of 1995, no persons are required to respond to a collection of information unless it displays a valid OMB control number.

12/31/99
JCS503 U.S. PTO

UTILITY PATENT APPLICATION TRANSMITTAL <i>(Only for new nonprovisional applications under 37 CFR 1.53(b))</i>	Attorney Docket No.	042390.P7832
	First Inventor or Application Identifier	Li-Shun Wang
	Title	REMOVAL OF RESIDUE FROM A SUBSTRATE
	Express Mail Label No.	EM560645885US

APPLICATION ELEMENTS See MPEP chapter 600 concerning utility patent application contents	ADDRESS TO: Assistant Commissioner for Patents Box Patent Application Washington, DC 20231
--	--

1. Fee Transmittal Form (e.g. PTO/SB/17)
(Submit an original, and a duplicate for fee processing)

2. Specification *Total Pages*
(preferred arrangement set forth below)

- Descriptive title of the Invention
- Cross References to Related Applications
- Statement Regarding Fed sponsored R & D
- Reference to Microfiche Appendix
- Background of the Invention
- Brief Summary of the Invention
- Brief Description of the Drawings (if filed)
- Detailed Description
- Claim(s)
- Abstract of the Disclosure

3. Drawing(s) (35 U.S.C. 113) *Total Sheets*

4. Oath or Declaration *Total Pages*

a. Newly executed (original copy)

b. Copy from a prior application (37 CFR 1.63(d))
(for continuation/divisional with Box 16 completed)

i. **DELETION OF INVENTOR(S)**
Signed statement attached deleting inventor(s) named in the prior application, see 37 CFR 1.63(d)(2) and 1.33(b).

5. Microfiche Computer Program (Appendix)

6. Nucleotide and/or Amino Acid Sequence Submission (if applicable, all necessary)

a. Computer Readable Copy

b. Paper Copy (identical to computer copy)

c. Statement verifying identity of above copies

ACCOMPANYING APPLICATION PARTS

7. Assignment Papers (cover sheet & document(s))

8. 37 CFR 3.73(b) Statement Power of Attorney
(when there is an assignee)

9. English Translation Document (if applicable)

10. Information Disclosure Statement (IDS)/PTO - 1449 Copies of IDS Citations

11. Preliminary Amendment

12. Return Receipt Postcard (MPEP 503)
(Should be specifically itemized)

13. *Small Entity Statement filed in prior application, Status still proper and desired

14. Certified Copy of Priority Document(s)
(if foreign priority is claimed)

15. Other:

*NOTE FOR ITEMS 1 & 13: IN ORDER TO BE ENTITLED TO PAY SMALL ENTITY FEES, A SMALL ENTITY STATEMENT IS REQUIRED (37 C.F.R. § 1.27), EXCEPT IF ONE FILED IN A PRIOR APPLICATION IS RELIED UPON (37 C.F.R. § 1.28).

16. If a **CONTINUING APPLICATION**, check appropriate box, and supply the requisite information below and in a preliminary amendment:

Continuation Divisional Continuation-in-part (CIP) of prior application No: _____ / _____

Prior application Information: Examiner _____ Group/Art Unit: _____

For **CONTINUATION** or **DIVISIONAL APPS** only: The entire disclosure of the prior application, from which an oath or declaration is supplied under Box 4b, is considered a part of the disclosure of the accompanying continuation or divisional application and is hereby incorporated by reference. The incorporation can only be relied upon when a portion has been inadvertently omitted from the submitted application parts.

17. CORRESPONDENCE ADDRESS

Customer Number of Bar Code Label or Correspondence address below

(Insert Customer No. or Attach bare code label here)

Name	BLAKELY, SOKOLOFF, TAYLOR & ZAFMAN LLP				
Address	12400 Wilshire Boulevard, Seventh Floor				
City	Los Angeles	State	California	Zip Code	90025
Country	U.S.A.	Telephone	(310) 207-3800	Fax	(310) 820-5988

Name (Print/Type)	Carol F. Barry, Reg. No. 41,600		
Signature		Date	12/31/99

Burden Hour Statement: This form is estimated to take 0.2 hours to complete. Time will vary depending upon the needs of the individual case. Any comments on the amount of time you are required to complete this form should be sent to the Chief Information Officer, Patent and Trademark Office, Washington, DC 20231. DO NOT SEND FEES OR COMPLETED FORMS TO THIS ADDRESS. SEND TO: Assistant Commissioner for Patents, Box Patent Application, Washington, DC 20231.

6047554

JCS503 U.S. PTO
09/476633
12/31/99

Attorney's Docket No. 042390.P7832
Express Mail No. EM560645885US

UNITED STATES PATENT APPLICATION

FOR

REMOVAL OF RESIDUE FROM A SUBSTRATE

Inventors:

Li-Shun Wang
John Chu

Prepared by:

BLAKELY SOKOLOFF TAYLOR & ZAFMAN LLP
12400 Wilshire Boulevard, Seventh Floor
Los Angeles, California 90025
(310) 207-3800

042390.P7832

BACKGROUND OF THE INVENTION

Field of the Invention

The invention relates generally to integrated circuits and more specifically to a method
5 and an apparatus for removing a particle from a portion of a metal layer over a substrate.

Description of Related Art

Integrated circuits are made up of literally millions of active devices formed in or on a
silicon substrate or well. The active devices that are initially isolated from one another are later
connected together to form functional circuits and components. The devices are interconnected
10 together through the use of well known multilevel interconnections. A cross-sectional illustration
of a typical multilevel interconnection structure 10 is shown in **Figure 1**. Interconnection
structures normally have a first layer of metallization, an interconnection layer 12 (typically
aluminum alloys with up to 3% copper), a second level of metallization 14, and sometimes a
third or even fourth level of metallization. Interlevel dielectrics 16 (ILDs), such as doped and
15 undoped silicon dioxide (SiO₂), are used to electrically isolate the different levels of metallization
in silicon substrate or well 18. The electrical connections between different interconnection levels
are made through the use of metallized vias 11 formed in ILD 16. In a similar manner, metal
contacts 22 are used to form electrical connections between interconnection levels and devices
formed in well 18. The metal vias 11 and contacts 22, hereinafter being collectively referred to as
20 "vias" or "plugs", are generally filled with tungsten 14 and generally employ an adhesion layer 16
such as TiN. Adhesion layer 16 acts as an adhesion layer for the tungsten metal layer 14 which

is known to adhere poorly to SiO₂. At the contact level, the adhesion layer acts as a diffusion barrier to prevent W and Si from reacting.

In one process, metallized vias or contacts are formed by a blanket tungsten deposition and a chemical mechanical polish (CMP) process. In a typical process, via holes 23 are etched through an ILD 24 to interconnection lines or a semiconductor substrate 26 formed below. Next, a thin adhesion layer 28, such as TiN, is generally formed over ILD 24 and into via hole 23, as shown in **Figure 2b**. Next, a conformal tungsten film 29 is blanket deposited over the adhesion layer and into the via hole 23. The deposition is continued until the via hole 23 is completely filled with tungsten. Next, the metal films formed on the top surface of ILD 24 are removed by CMP, thereby forming metal vias or plugs 28.

In a typical CMP process as shown in **Figure 2c**, the substrate or wafer 30 is placed face-down on a polishing pad 32 which is fixedly attached to a rotatable platen 34. In this way, the thin film of a metal layer to be polished (*i.e.*, tungsten film 29) is placed in direct contact with pad 32. A carrier 36 is used to apply a downward pressure F_1 against the backside of substrate 30. During the polishing process, pad 32 and platen 34 are rotated while a downward force is placed on substrate 30 by carrier 36. An abrasive and chemically reactive solution, commonly referred to as "slurry" 35 is introduced onto pad 32 during polishing. Slurries generally include an abrasive material such as alumina or silica. The slurry initiates the polishing process by chemically reacting with the film being polished. The polishing process is facilitated by the rotational movement of pad 32 relative to wafer 30 as slurry is provided to the wafer/pad interface. Polishing is continued in this manner until all of the film on the insulator is removed.

After polishing, the substrate is generally rinsed with a solution such as deionized water in order to remove particles that remain on the substrate after the CMP operation. Conventional rinsing methods include using a scrubber with deionized water. However, high-speed spin rinse generally does not remove all of the particles. Another conventional method is a “magasonic” bath that involves high frequency vibration in which particles are shaken off the substrate. This method also leaves particles on the metal layer.

To properly form multiple layers of interconnect and to increase die yield, it is necessary to reduce particles that may block electrical conduction from one metal layer to another metal layer. If a particle is on a via, there is no electrical connection between the area where the particle is located and the metal layer. Accordingly, removing as many particles from a metal layer reduces the failures that may occur in an integrated circuit.

Another way in which the integrity of the metal layer may be affected relates to the removal of the metal layer during the polishing process. In removing particles, it must be ensured that a metal layer is not removed to a level such that a gap exists between a metal layer subsequently deposited onto the via or contact which may affect electrical conduction between the metal layer and the via.

Despite advances that have been made in removing particles from metallized plugs in contacts and vias, there are still failures that occur in integrated circuits due to inadequate removal of particles from a metal layer. It is therefore desirable to have a method that efficiently removes particles from a metal layer and simplifies the conventional processes used.

SUMMARY OF THE INVENTION

A method and an apparatus for polishing a metal layer on a substrate is disclosed. A rinsing solution comprising hydrogen peroxide is introduced onto the metal layer.

042390.P7832

BRIEF DESCRIPTION OF THE DRAWINGS

The features, aspects, and advantages of the invention will become more thoroughly apparent from the following detailed description, appended claims, and accompanying drawings.

Figure 1 is a cross-sectional illustration showing a portion of a standard multilevel
5 integrated circuit.

Figure 2a is a cross-sectional illustration showing the formation of a via hole through an insulating layer formed on a conductive layer of a semiconductor substrate.

Figure 2b is a cross-sectional illustration showing the formation of an adhesion layer and a tungsten layer on the substrate of **Figure 2a**.

10 **Figure 2c** is a cross-sectional illustration of a chemical mechanical polishing apparatus used to polish the films formed on the substrate of **Figure 2b**.

Figure 3 is a cross-sectional view of a substrate in which a metal layer is deposited thereon filling an opening or via with a metal in accordance with an embodiment of the invention.

15 **Figure 4** is a cross-sectional view of the device in **Figure 3** after the device has undergone polishing in accordance with an embodiment of the invention.

Figure 5 shows a particle that is located in a recessed region of a metal layer.

Figure 6 shows that the particle has been removed by using a solution comprising hydrogen peroxide.

Figure 7 shows the device as in **Figure 6** in which a metal has been deposited thereon.

20 **Figure 8** shows a polisher that may be used in accordance with an embodiment of the invention.

Figure 9 shows a picture of a particle located within a recessed region of a metal layer.

042390.P7832

Figure 10 shows that the particle has been removed after the wafer has been rinsed with a solution containing hydrogen peroxide.

Figure 11 is a flow chart of one embodiment of the invention.

042390.P7832

DETAILED DESCRIPTION OF THE INVENTION

The following detailed description and the accompanying drawings are provided for the purpose of describing and illustrating presently preferred embodiments of the invention only, and are not intended to limit the scope of the invention.

5 One embodiment of the invention relates to a method and an apparatus for removing a particle from a metal layer. A slurry is introduced over the metal layer and the metal layer is polished. The metal layer is then rinsed with a solution that comprises hydrogen peroxide.

Figures 3-7 show one embodiment of the invention in which a particle that is trapped in a recessed region in metal layer is removed using a solution comprising hydrogen peroxide. In

10 **Figure 3**, substrate 40 has an interlayer dielectric (“ILD”) 42 deposited thereon. Via hole 48 is formed in ILD 42 using conventional techniques such as photolithographic techniques. Substrate 40 is used in fabricating semiconductor devices or to make contact with other metal layers. A layer of adhesion material 47 such as titanium (Ti) or titanium nitride (TiN) is formed on ILD 42 to improve the adhesion between ILD 42 and metal layer 44. Metal layer 44 comprises, for
15 example, tungsten or other suitable metal (*e.g.* copper, aluminum, etc.) deposited over adhesion material layer 47 in via hole 48.

Figure 4 shows the structure of **Figure 3** after the surface of the structure has undergone a CMP operation and a portion of metal layer 44 has been removed outside of via hole 48. Due to the polishing operation, recess 50 is generally formed in the via. The slurry (also referred to
20 herein as a first agent) comprises an abrasive material such as alumina, silica, ceria, zirconia or other suitable material. The abrasive material comprises approximately in the range of 2 to 5%

by weight of the slurry. The slurry may also contain a chemical reagent such as hydrogen peroxide and nitric acid.

Figure 5 shows particle 60 trapped in recess 50 of substrate 10. Particles such as particle 60 occur from a variety of sources. For example, in a polishing process, a slurry comprising an abrasive material is used. The abrasive material may remain on the metal layer after the polishing operation has been completed. Particles may also be present due to debris generated during the polishing operation.

Figure 6 shows the structure of **Figure 5** after the surface of adhesion material layer 47 and metal layer 44 has been rinsed with a solution (also referred to herein as a second agent) and particle 60 has been driven into the solution and removed from recessed region 50.

The substrate may be rinsed by spraying the substrate. An alternative embodiment to spraying the solution includes using a bath in which the substrate is submerged into a bath containing the rinsing solution. Additionally, the rinsing solution may be introduced through the polisher.

In one embodiment, the rinsing solution comprises approximately 4% by volume of hydrogen peroxide, and generally comprises hydrogen peroxide in the approximate range of 2% to 4.5%. The upper limit of hydrogen peroxide concentration is that amount that removes too much of metal layer 44 such that the reliability of the wafer is affected. The remainder of the rinse contains deionized water. In the operation, if a 4% by volume hydrogen peroxide solution is introduced onto a tungsten material, a removal rate of approximately 60Å/minute is achieved. The removal rate generally ranges from approximately 20 to 80 Å/minute.

The rinsing solution comprises deionized water and the hydrogen peroxide that is introduced onto the polishing pad occurs at a pressure of approximately 0.5 to 2 psi and flow rate of 50 to 300 cc/minute. For example, the flow rate of the solution is approximately 200 cc/minute for approximately 30 seconds. Preferably, the solution containing hydrogen peroxide and deionized water may be mixed or combined in a container as a separate operation. The solution that has the desired ratio of hydrogen peroxide to deionized water is placed into a container (not shown) that is attached to the polisher. This allows the solution to be fed into the polisher. Alternatively, the hydrogen peroxide and the deionized water may be separately introduced into the polisher at such a volumetric rate that the correct ratio of hydrogen peroxide to deionized water is met prior to the solution contacting the substrate.

In one aspect, the duration of the polishing in the rinse operation is directly proportional to the amount of particles that are to be removed. For example, if the metal layer is believed to be heavily contaminated with particles, polishing may take up to 60 seconds. However, if few particles are on the substrate, polishing may take less than 10 seconds. During the polishing operation in the rinse operation, the rate at which metal layer is removed is approximately 60Å/minute.

The polishing pressure in the rinse operation with which carrier 140 presses polishing pad 120 onto interconnection layer 70 is generally in the range of approximately 0.5 to 2 psi and is preferably maintained at about 1.0 psi. It is desirable to use a lower polish rate (*e.g.*, less than 60 Å/minute) in order to avoid creating a large recessed region that may cause the integrated circuit to fail.

Figure 7 shows interconnection layer 70 which is a metal material selected from the group comprising of aluminum, copper, tungsten, and the like, is deposited over adhesion material layer 47 and metal layer 44. Interconnection layer 70 is patterned into lines using photoresistant etching such as photolithography and etching. Since particles such as particle 60 were removed from the substrate before another layer of metal was deposited over adhesion material layer 47, the electrical conduction is not blocked by foreign particles. Accordingly, the device fabricated by the process described herein reduces the amount of possible failures that may occur with integrated circuits.

Figure 8 shows a polisher that may be used in the polishing process. Polishing involves at least one polisher 100 comprising a carrier 140, a polishing pad 120, and a platen 130. Carrier 140 holds substrate 5. Platen 130 holds polishing pad 120 in place.

Polishing pad 120 may use a dual layer polishing pad wherein the top pad of the polishing pad may comprise polyurethane and the bottom pad may comprise a hard material, for example, polyester fiber. Polishing pad 120 is generally conditioned with a conditioner brush prior to the polishing operation.

The polishing operation is accomplished by bringing the substrate placed in a solid retaining ring (not shown) into contact with the polishing pad 120. Carrier 140 presses substrate 5 onto polishing pad 120. Carrier 140 and polishing pad 120 are then rotated. It will be appreciated that because carrier 140 is holding substrate 5 by using a slotted retaining ring (not shown), substrate 5 is rotated against the polishing pad 120 to polish the surface of the metal layer on substrate 5. Polishing pad 120 contacts the metal layer and removes the portion of the

metal layer not extending into the via. Polishing pressures for this process are generally in the range of approximately 3 to 6 psi.

A temperature of around 20°C to 25°C of the platen/polishing pad may be used during the polishing process. It will be appreciated, however, that the invention can be practiced at a variety of temperatures depending upon the composition of the metal layer and the substrate. The temperatures of the process may be controlled by refrigerating the slurry and polishing pad.

The rotation of polishing pad 120 (polishing pad rotation) and the rotation of carrier 140 (carrier rotation) are also controlled. Polishing pad 120 is rotated at approximately 50 to 500 rpm and carrier 140 is rotated at approximately 10 to 100 rpm. Preferably, the carrier rotation is maintained at approximately 50 rpm and the polishing pad rotation is maintained at approximately 250 rpm.

Figures 9 and 10 show particles on the substrate and substrate after the particles have been removed. **Figure 9** shows a picture of a substrate having a metal layer wherein particles are located thereon after a conventional high-speed rinse post-polish was used. **Figure 10** shows that no particles remain on the metal layer after the process described herein has been used.

Figure 11 shows the operations used to perform one embodiment of the invention. At operation 200, vias or contacts are formed in the substrate and an adhesion layer that serves as a barrier layer is deposited thereon. At operation 210, the substrate having a metal layer deposited thereon is placed in a slotted ring (not shown) of a polisher. At operation 220, a slurry is placed onto the polishing pad and the polishing pad contacts the metal layer coupled to the substrate. At operation 230, the metal layer is polished using polishing means such as described above. At

operation 240, a solution comprising hydrogen peroxide is deposited over the substrate. At operation 250, at least one or more particles is removed from the metal layer on the substrate.

In the preceding detailed description, the invention is described with reference to specific embodiments thereof. It will, however, be evident that various modifications and changes may be made thereto without departing from the broader spirit and scope of the invention as set forth in the claims. The specification and drawings are, accordingly, to be regarded in an illustrative rather than a restrictive sense.

042390.P7832

CLAIMS

What is claimed is:

- 1 1. A method of removing a particle from a metal layer over a substrate comprising:
2 depositing a first agent onto the substrate;
3 polishing the metal layer with the first agent; and
4 introducing a second agent comprising hydrogen peroxide onto the metal layer.
- 1 2. The method of claim 1, wherein polishing the metal layer comprises polishing a metal
2 material selected from the group consisting of tungsten and copper.
- 1 3. The method of claim 1, wherein polishing the metal layer comprises polishing with the
2 first agent having an abrasive material selected from the group consisting of silica, alumina,
3 zirconia, and ceria.
- 1 4. The method of claim 1, wherein polishing comprises chemical mechanical polishing.
- 1 5. The method of claim 1, wherein introducing the second agent occurs after the operation of
2 polishing the metal layer and the substrate.
- 1 6. The method of claim 1, wherein introducing the second agent comprises introducing a
2 second agent of approximately 4% by volume or less of hydrogen peroxide.
- 1 7. The method of claim 1, further comprising polishing the substrate with the second agent.
- 1 8. The method of claim 1, wherein polishing the metal layer with the second agent includes
2 polishing with a polisher operating at a polishing pressure approximately in the range of 0.5 to
3 2.0 psi.
- 1 9. A method of removing at least one particle from a portion of a metal layer on a substrate
2 comprising:

042390.P7832

- 3 depositing a slurry onto the substrate;
- 4 polishing the metal layer and the substrate; and
- 5 rinsing the substrate with a solution comprising hydrogen peroxide.

- 1 10. The method of claim 9, wherein polishing the metal layer comprises polishing a metal
2 material selected from the group consisting of tungsten, copper, and aluminum.

- 1 11. The method of claim 9, wherein depositing the slurry further comprises depositing a
2 slurry having an abrasive material selected from the group consisting of silica, alumina, zirconia,
3 and ceria.

- 1 12. The method of claim 9, wherein rinsing the substrate occurs after polishing the metal layer
2 and substrate.

- 1 13. The method of claim 9, wherein rinsing the substrate comprises rinsing with the solution
2 which comprises approximately 4% by volume or less of hydrogen peroxide.

- 1 14. The method of claim 9, wherein polishing the metal layer includes removing the metal
2 layer at a rate of approximately in the range of 40Å/minute to 80Å/minute.

- 1 15. The method of claim 9, wherein polishing comprises chemical mechanical polishing.

- 1 16. The method of claim 9, wherein rinsing occurs during polishing; and
2 polishing comprises polishing with a polisher at a polishing pressure approximately in the
3 range of 0.5 to 2.0 psi.

- 1 17. The method of claim 16, wherein the metal layer is removed at a rate of 60Å/minute.

- 1 18. A method of polishing a metal layer on a substrate comprising:
2 polishing the metal layer and introducing a rinsing solution onto the metal layer, the
3 rinsing solution comprising hydrogen peroxide.

1 19. The method of claim 18, further including polishing the substrate with an abrasive
2 material, wherein the rinsing solution is introduced after a polishing of the substrate.

1 20. The method of claim 18, wherein introducing a rinsing solution comprises introducing a
2 rinsing solution of approximately 4% by volume or less of hydrogen peroxide.

1 21. The method of claim 18, wherein introducing a rinsing solution occurs during polishing the
2 metal layer in which a polishing pressure is used approximately in the range of 0.5 to 2.0 psi.

1 22. The method of claim 18, wherein a metal layer is removed at a rate of 60Å/minute.

042390.P7832

ABSTRACT OF THE DISCLOSURE

A method and an apparatus of removing a particle from a metal layer over a substrate is disclosed. The method comprises introducing a slurry onto the metal layer and polishing the metal layer. A solution comprising hydrogen peroxide is introduced onto the metal layer and at

5 least one particle is removed from the metal layer.

042390.P7832

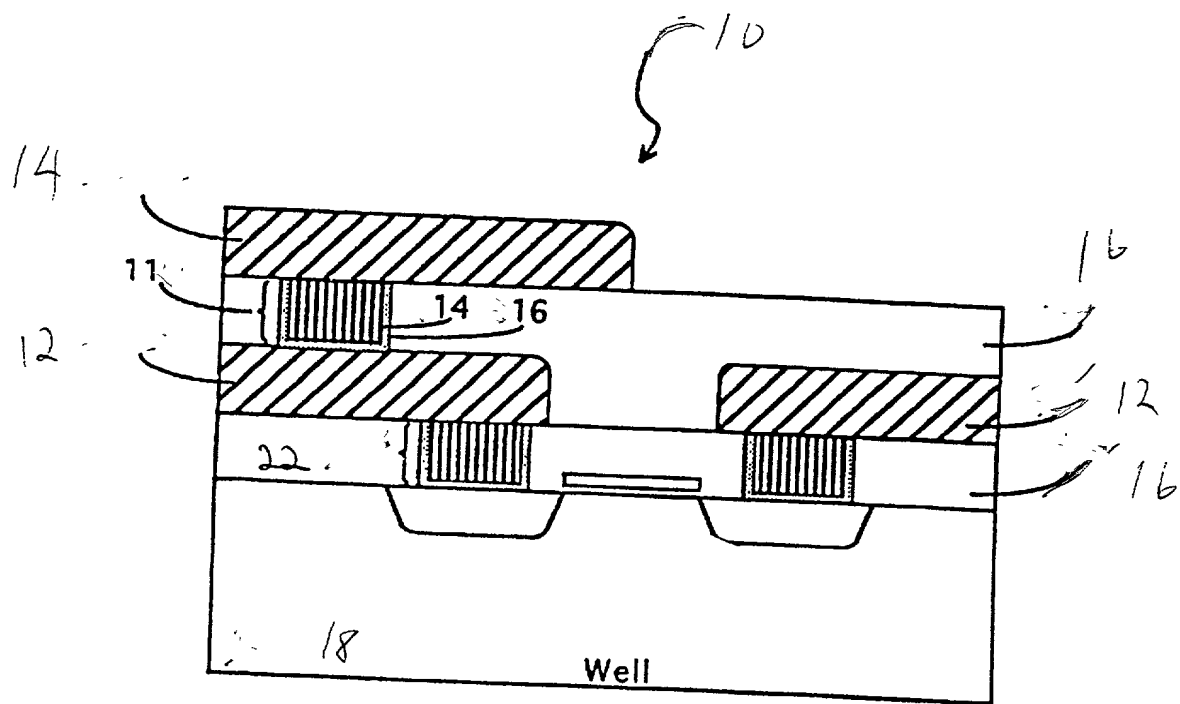

Figure 1 (Prior Art)

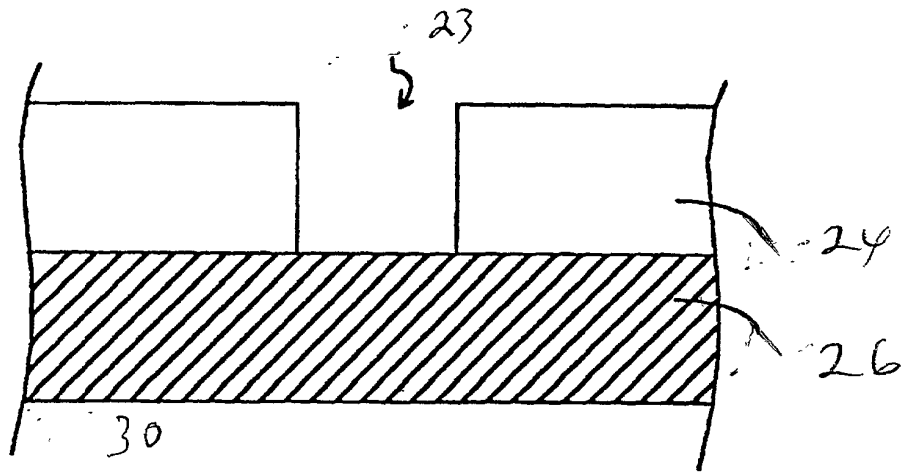

Figure 2a (Prior Art)

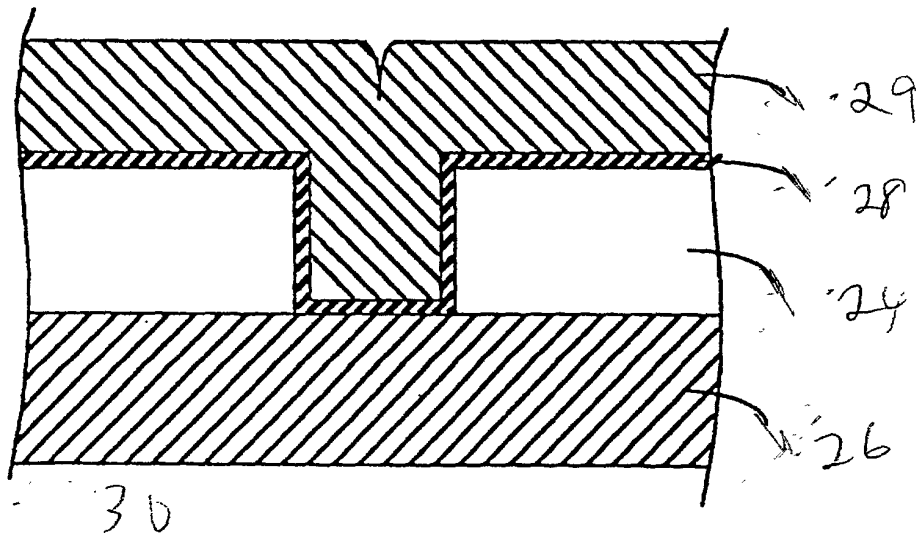

Figure 2b (Prior Art)

2025 RELEASE UNDER E.O. 14176

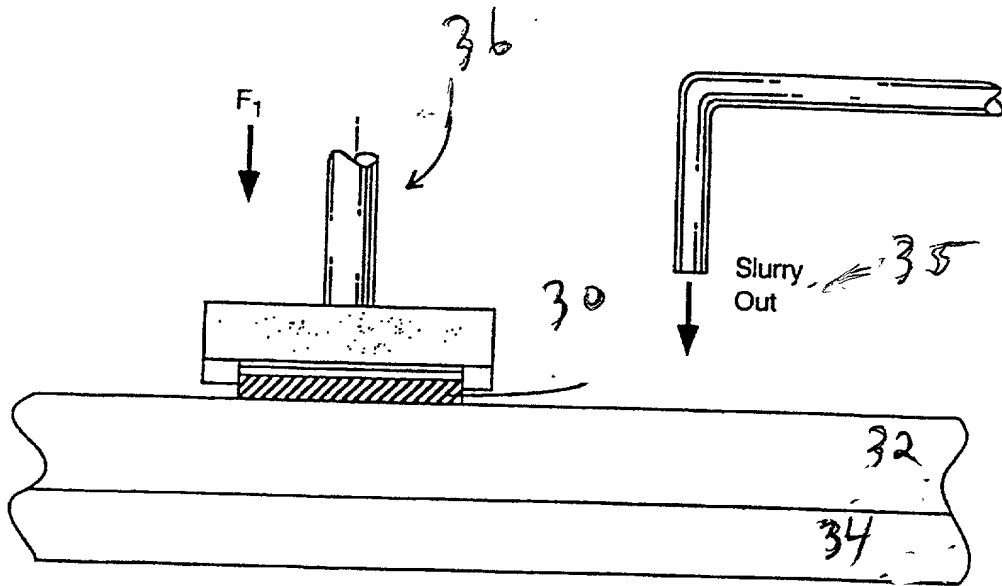

Figure 2c (Prior Art)

SECRET

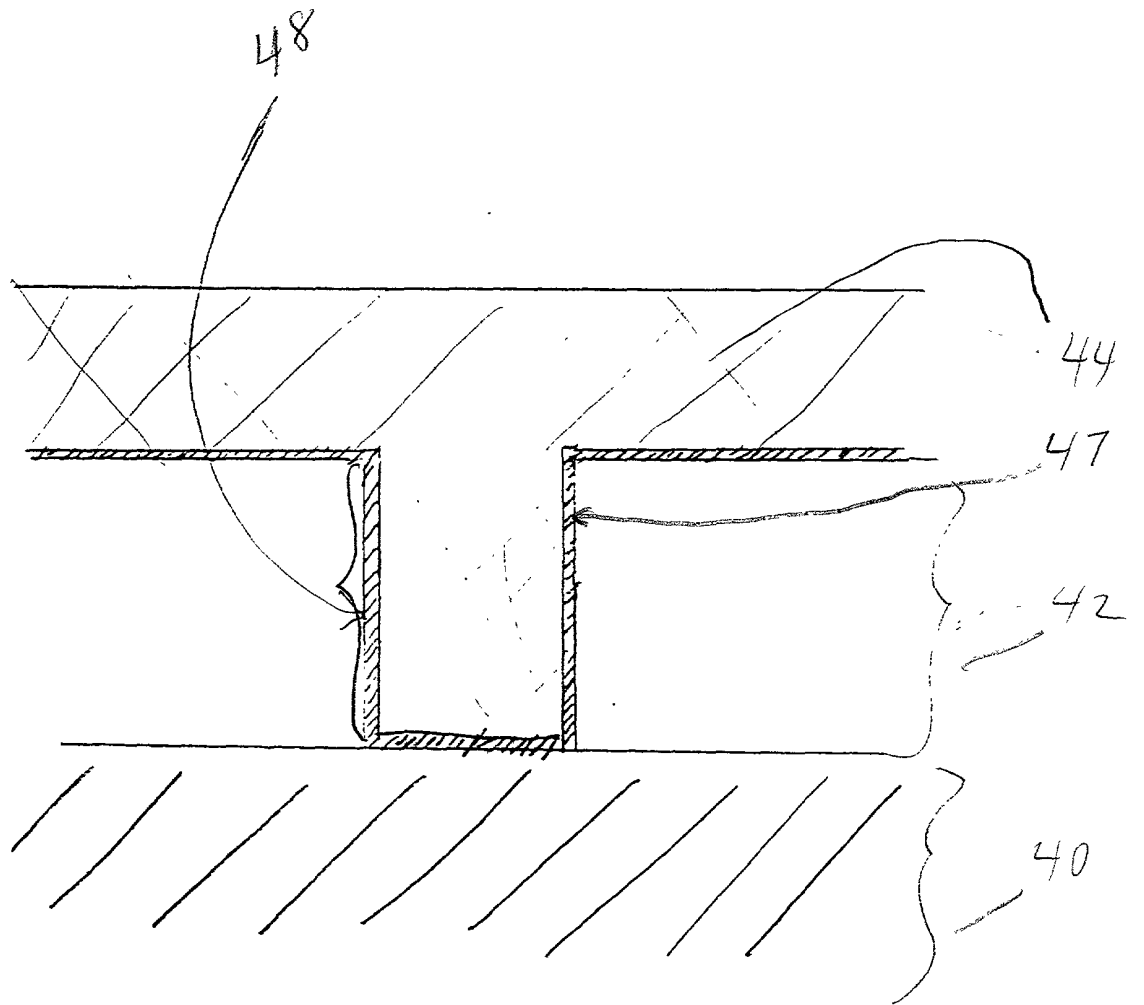

FIG. 3

66767 669460

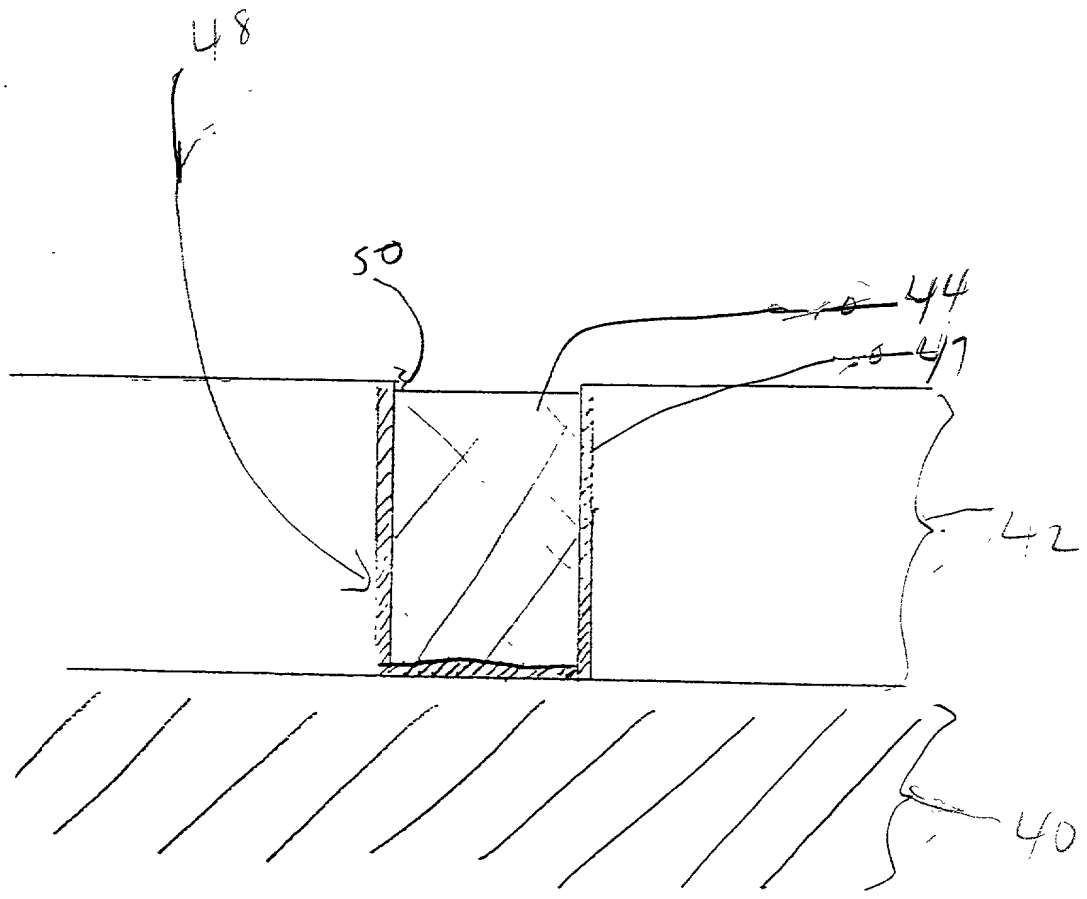

FIG. 4

009663-12499

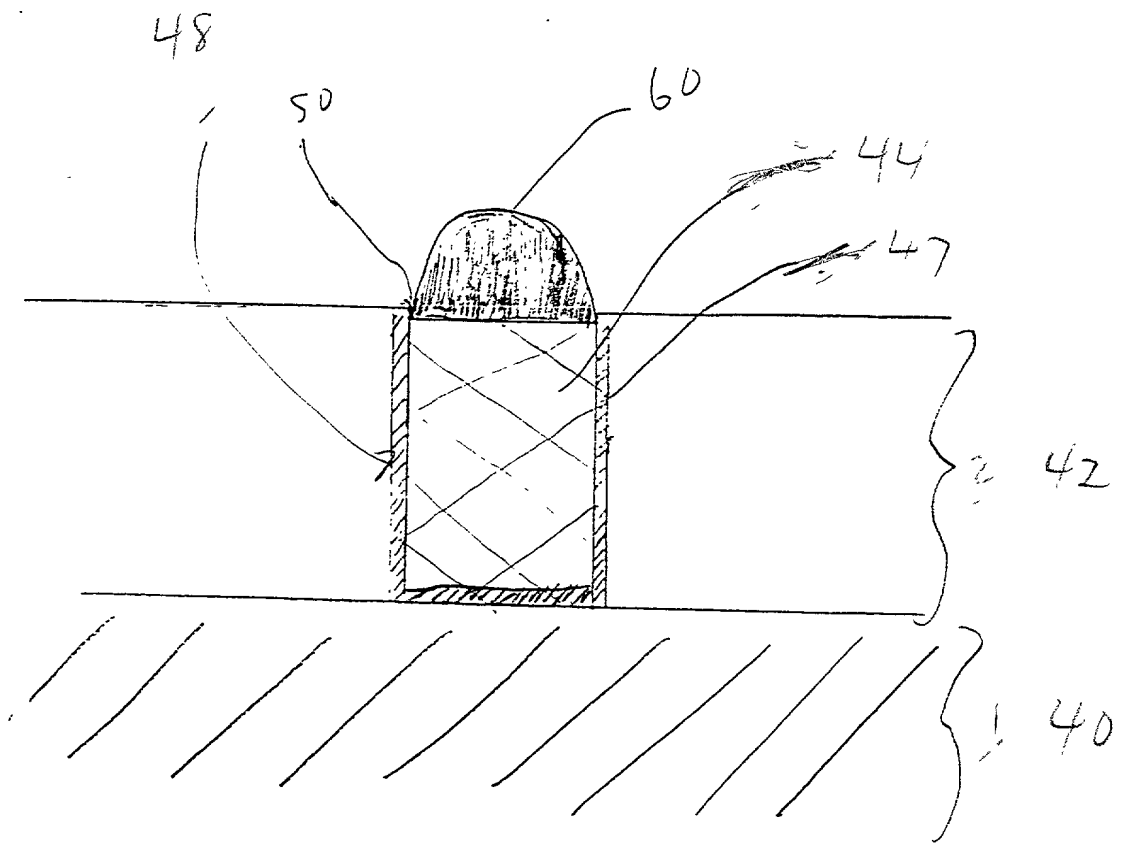

FIG. 5

66767 699460

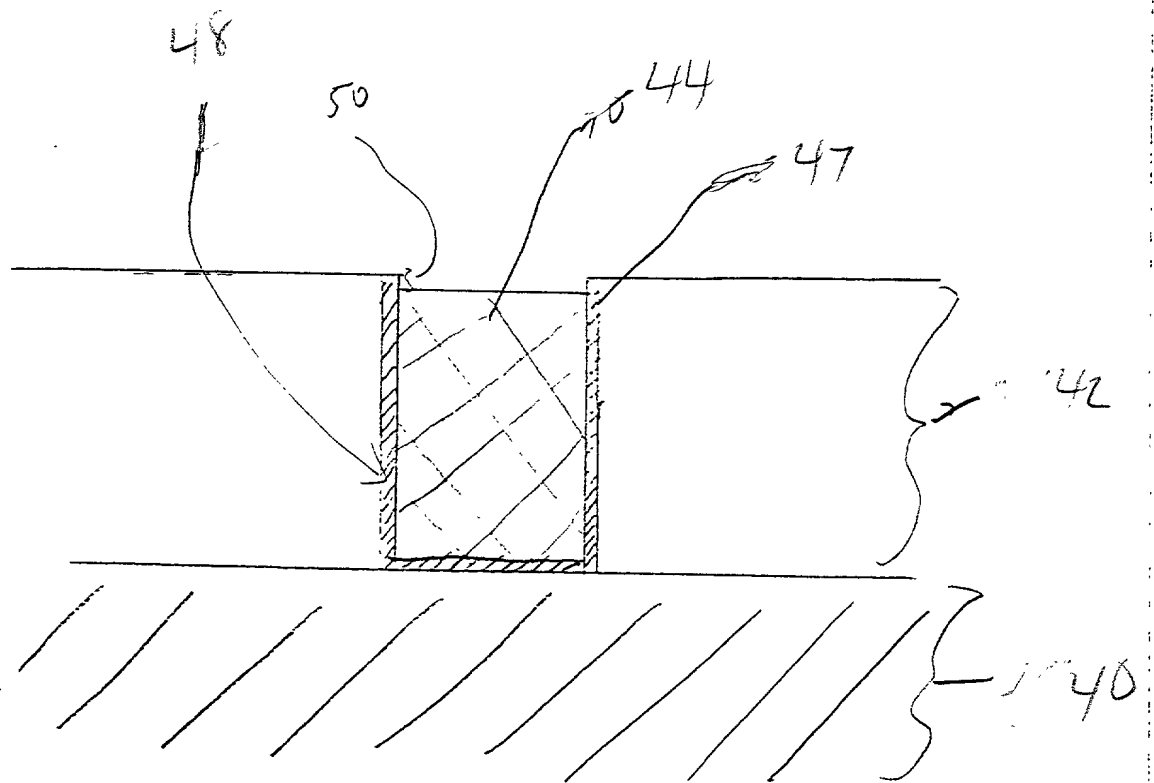

FIG. 6

66767-1-100

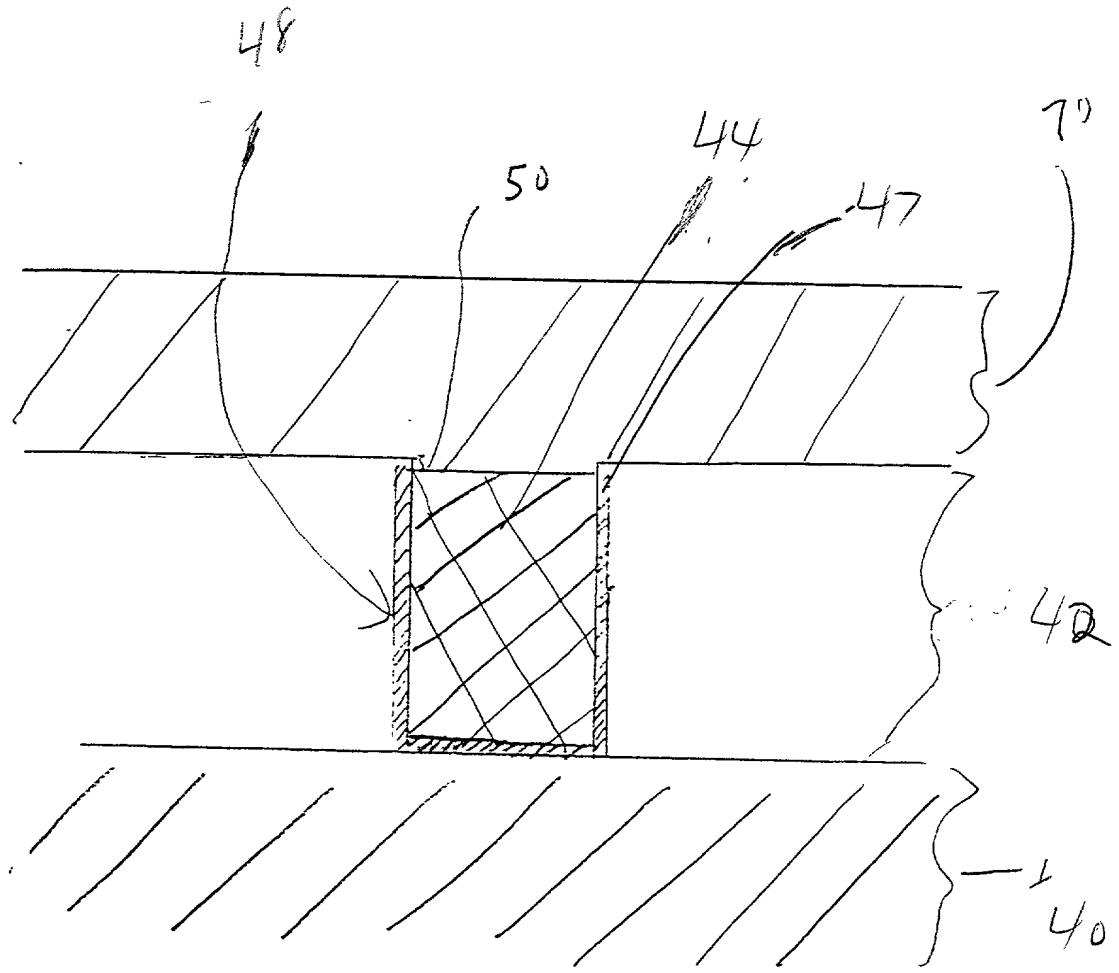

FIG. 7

SECRET

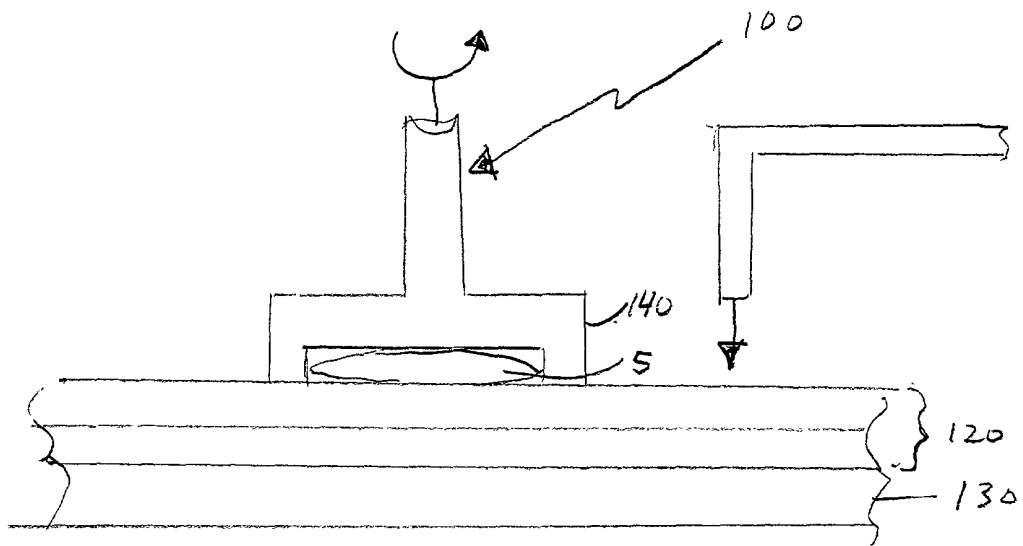

FIG. 8

0094633-4349

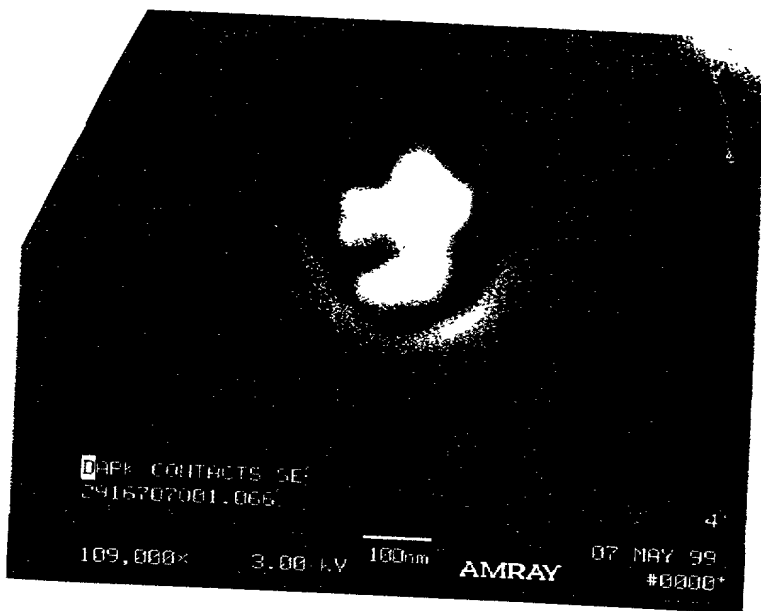

Fig. 9

667667 094760

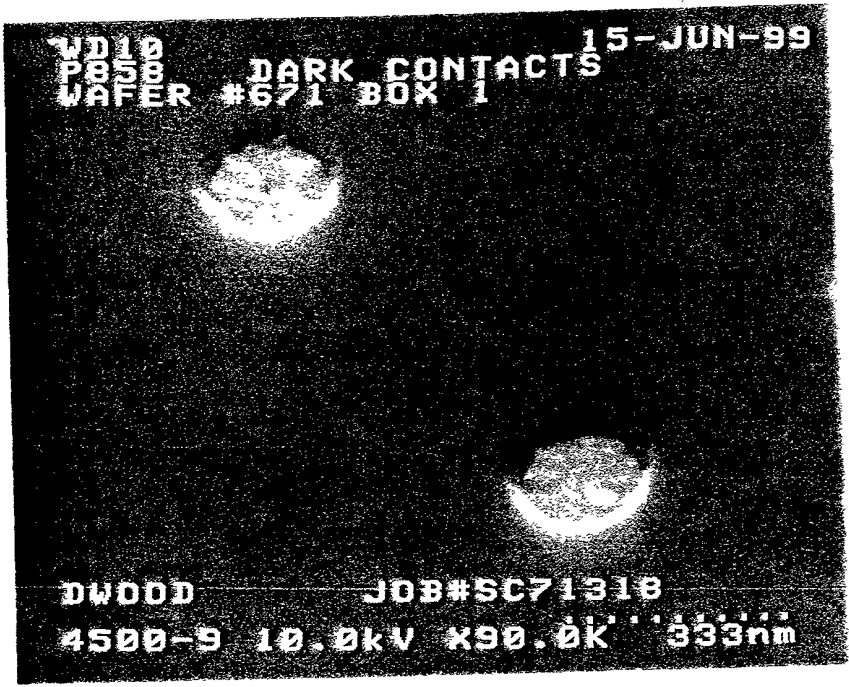

FIG. 10

SECRET

Vias or contacts are
formed in the substrate

200

FIG. 91

60767 659460

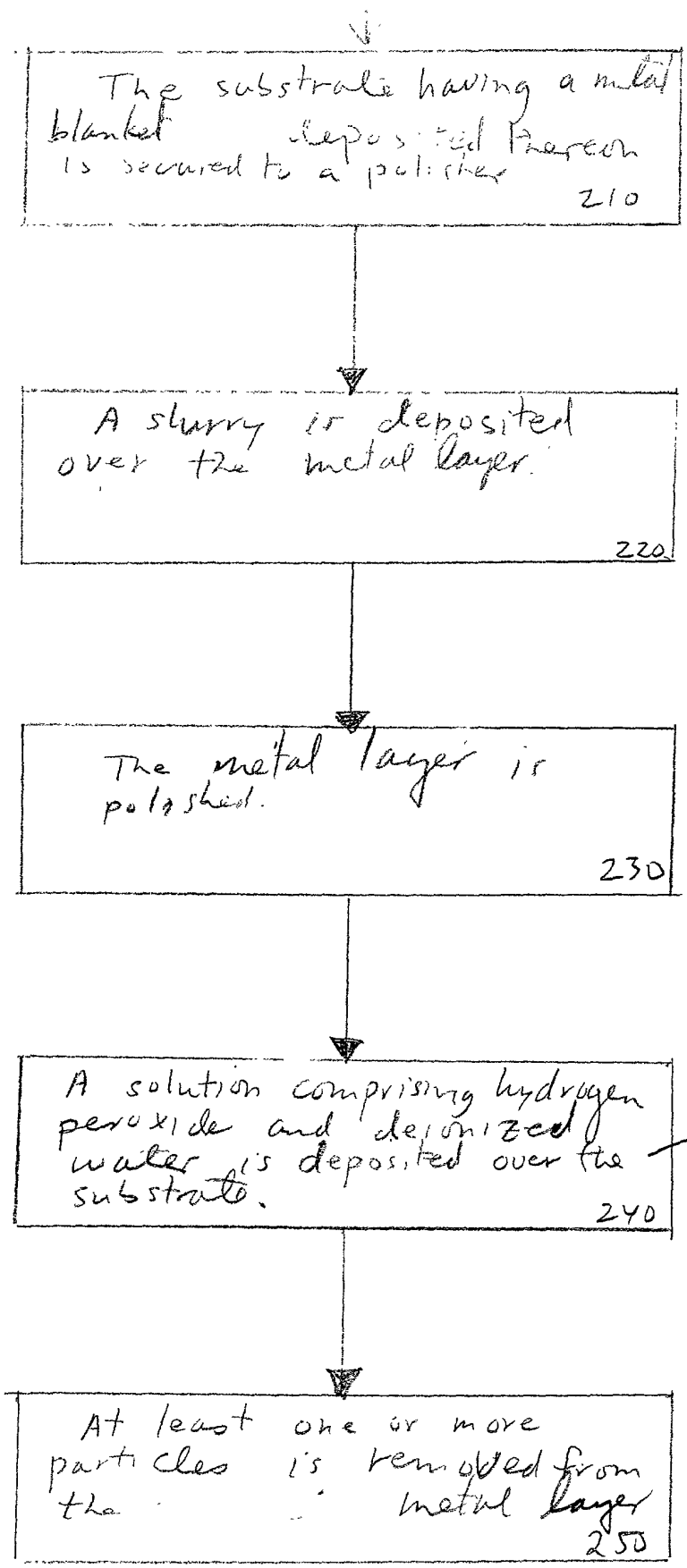

metal layer on the

FIG. 11